

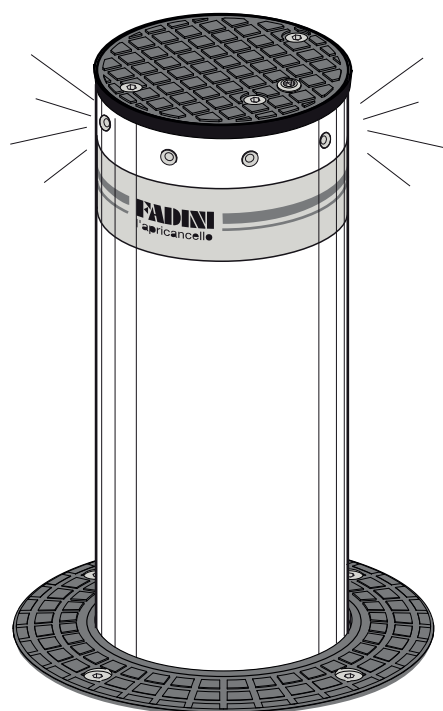

Strabuc 918

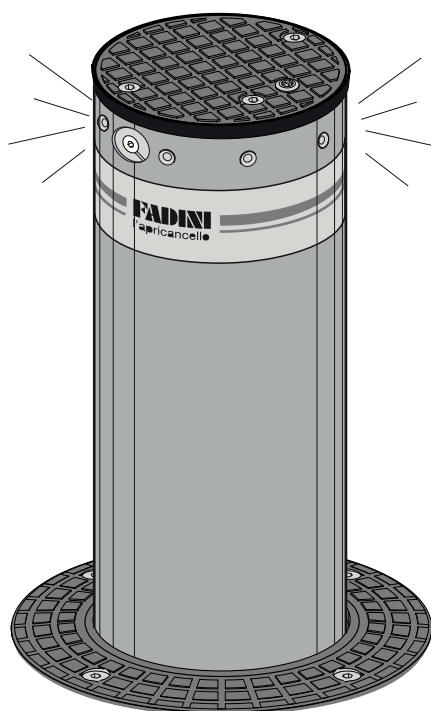

Strabuc 930



EN 13241
EN 12453
EN 12445



FADINI
the gate opener
made in Italy

FOR OPTIMAL APPLICATION AND USE OF THE STRABUC 918 AND STRABUC 930 PLEASE READ THE INSTRUCTIONS AND CONSULT EXPLANATORY DIAGRAMS.

IMPORTANT: ALL INSTALLATION OPERATIONS MUST BE PERFORMED BY A QUALIFIED TECHNICIAN, IN OBSERVANCE OF THE EN 12453 - EN 12445 SAFETY REGULATIONS AND MACHINERY DIRECTIVE 2006/42/CE. CAREFUL RISK ANALYSIS IS REQUIRED UNDER APPLICABLE REGULATIONS.

GENERAL COMMENTS

STRABUC 918 and **STRABUC 930** are a fully retractable, belowground, oil-hydraulic steel traffic control post intended to prevent unauthorised vehicular access. It is an oil-hydraulic operator with a built-in hydraulic main unit. The Elpro S40 electronic programmer is installed externally, in a protected place. The traffic control post comes with a series of accessories that guarantee the necessary safety and the required operations, in order to make the operator suitable for installation in all public and private settings.

STRABUC 918: bollard with retractable post of steel, 4 mm thickness. Stainless steel option available. For both versions an optional electro/solenoid-valve is possible for automatic lowering in case of power failure.

STRABUC 930 HEAVY ARMoured: bollard with retractable post of steel, 12 mm thickness. On request the unit can be fitted with an electro/solenoid-valve for automatic lowering in case of power failure, and an armoured lock barrel, removable only by a custom-made key, to provide burglar-proof extra security to the post.

PRELIMINARY WARNINGS ON SAFETY AND GOOD OPERATION

Before commencing operator installation, it is essential to remember:

- That installation, checking, testing, risk analysis and subsequent maintenance work must be performed by authorised, qualified technicians.
- This operator has been designed for the use described in this manual only, and using at least the safety, control and indication accessories as here recommended.
- Any other application not explicitly indicated in this manual could cause malfunction, damage or personal injury.
- To check that the ground is stable, to avoid subsequent settling or deformation in the traffic control post installation area.
- To check that there are no nearby buried utility pipes.
- To check that there are no sources of electromagnetic disturbance in the immediate vicinity of and below the installation accessories such as to conceal or influence the magnetic/electromagnetic detection of the metal detectors and/or other electronic system control and management appliances.
- To check that the mains supply and voltage to the electric motor is 230 V at 50 Hz.
- The power supply to the operators are built-in motor must be made using electricity cables with a 1,5 mm² section for a maximum distance of 50 metres. For distances of over 50 metres, use electric cables with sections suited to the installation.
- Always use the original components indicated by the manufacturer to replace elements or accessories.
- Meccanica Fadini declines all responsibility for improper use not specifically indicated in this manual and any malfunction deriving from the use of materials or accessories other than those indicated by the manufacturer.
- The manufacturer reserves the right to make changes to this manual without giving notice.

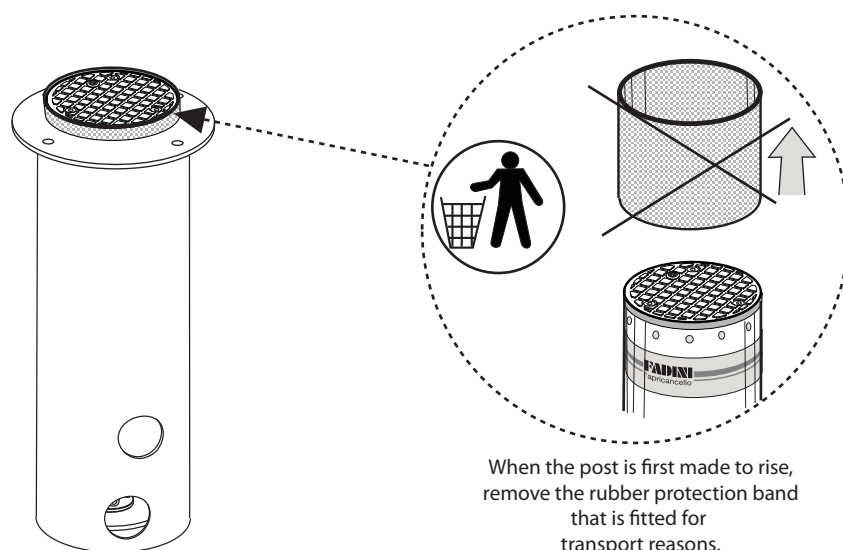

The manufacturer, Meccanica Fadini, is not responsible for non-observance of good installation practice and applications not indicated in this manual.

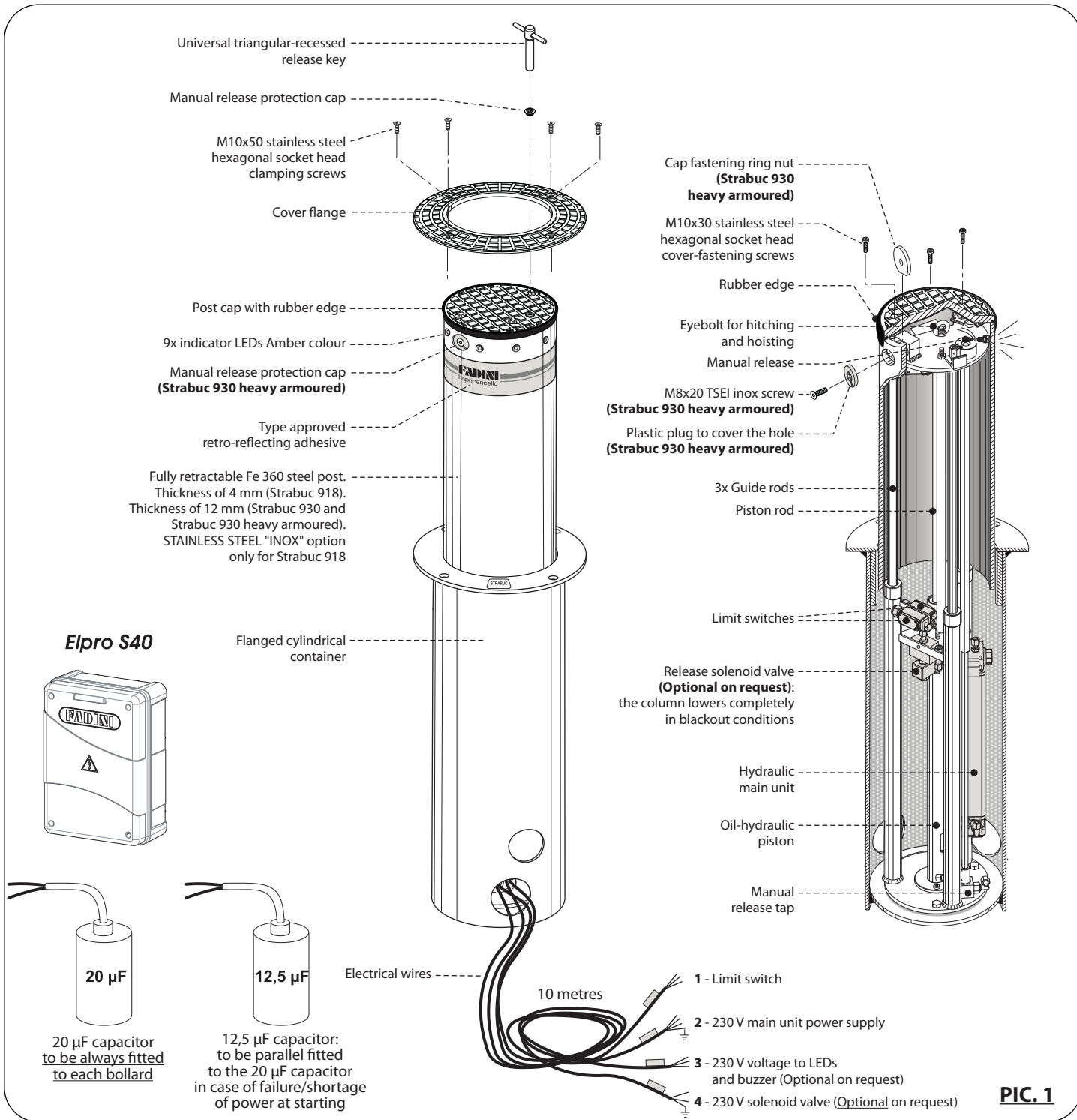

STRABUC 930

Version of the Strabuc heavy bollard, 12 mm thickness, without security armoured lock barrel.

STRABUC 930 HEAVY ARMOURED

Version with armoured lock barrel (optional) that can only be removed using the personalised key, which lends the traffic post greater protection against forced entry (Pic. 2).

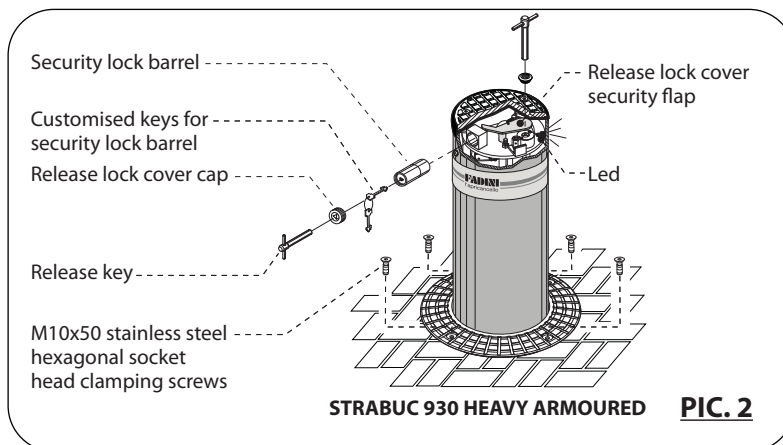

OPTIONAL ACCESSORIES FOR COMPLETE INSTALLATION

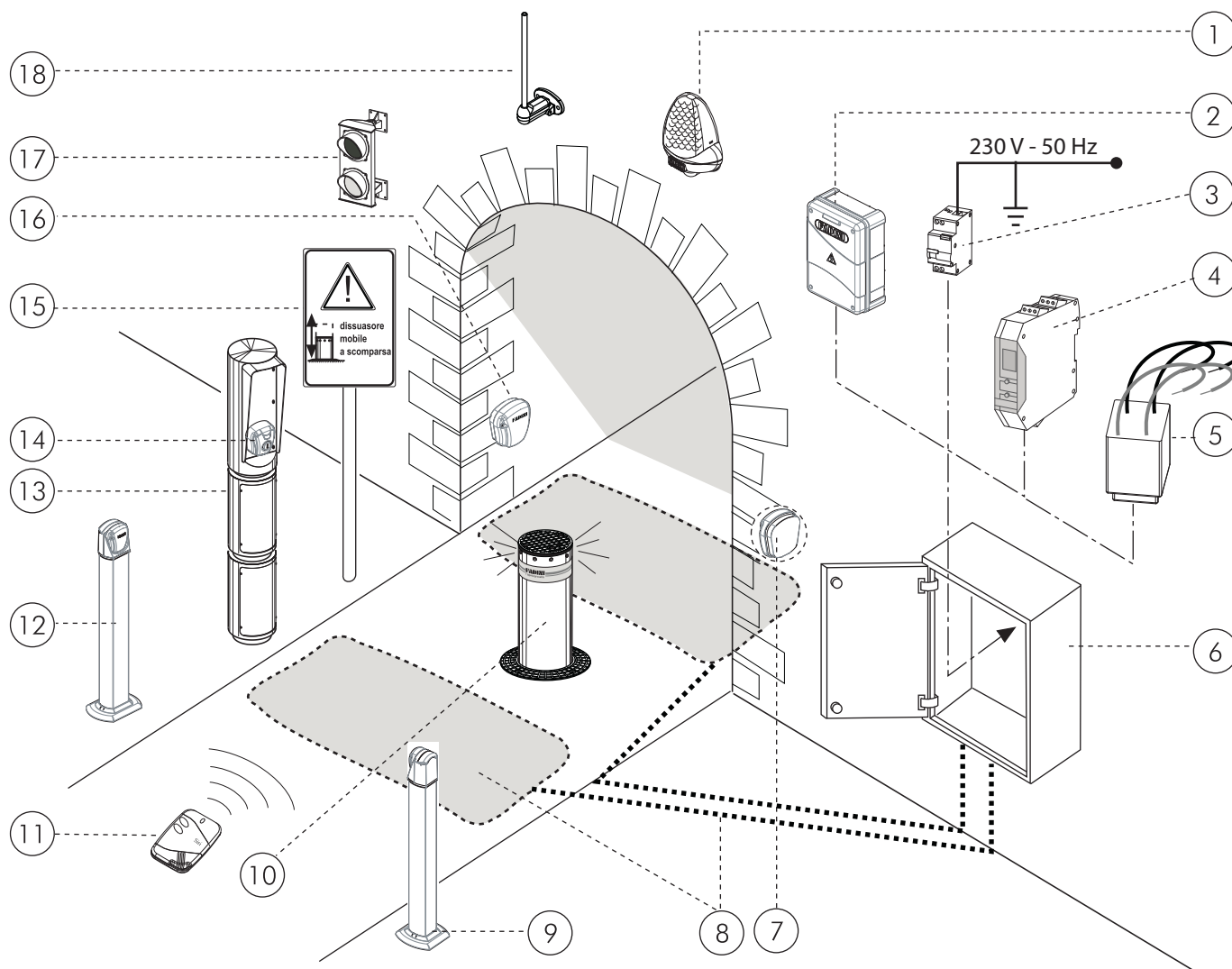

List of all operative accessories available:

- 1 - Miri 4 Led flashing light
- 2 - Elpro S40 electronic programmer with Siti 63 radio receiver
- 3 - Thermomagnet differential switch with sensitivity 0,03 A (not provided)
- 4 - Two-channel metal mass detector
- 5 - Voltage stabilizer for each single solenoid/electro-valve coil
- 6 - Anti-intrusion cabinet
- 7 - Fit 55 recess-mounted photoelectric cell receiver
- 8 - Pre-assembled magnetic loop with power supply cable
- 9 - Post for Fit 55 photoelectric cell projector
- 10 - Strabuc 918 or Strabuc 930 oil-hydraulic traffic control post
- 11 - Siti 63 Transmitter
- 12 - Post for Fit 55 photoelectric cell receiver
- 13 - Visual 344 control accessory housing post
- 14 - Chis 37 key switch
- 15 - Post moving hazard-warning indicator
- 16 - Recess-mounted Fit 55 photoelectric cell projector
- 17 - Two-light traffic lights
- 18 - Birio A8 wall-mounted aerial
- 19 - Strabuc housing to be cemented into the ground (standard issue)

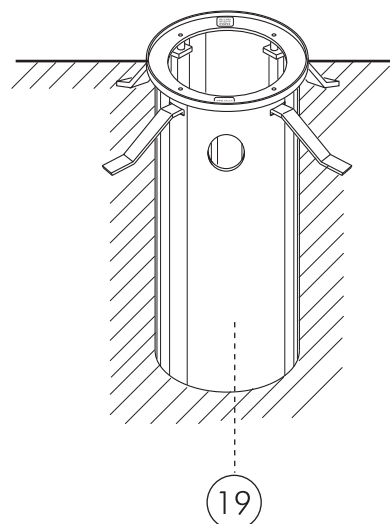

PIC. 3

INSTALLATION OF THE CYLINDRICAL HOUSING TO BE CEMENTED INTO THE GROUND

- Assemble the **support plates** to be cemented into the ground by fitting them inside the slots in the **cylindrical container** and fasten them by the provided screws (Pic. 4).

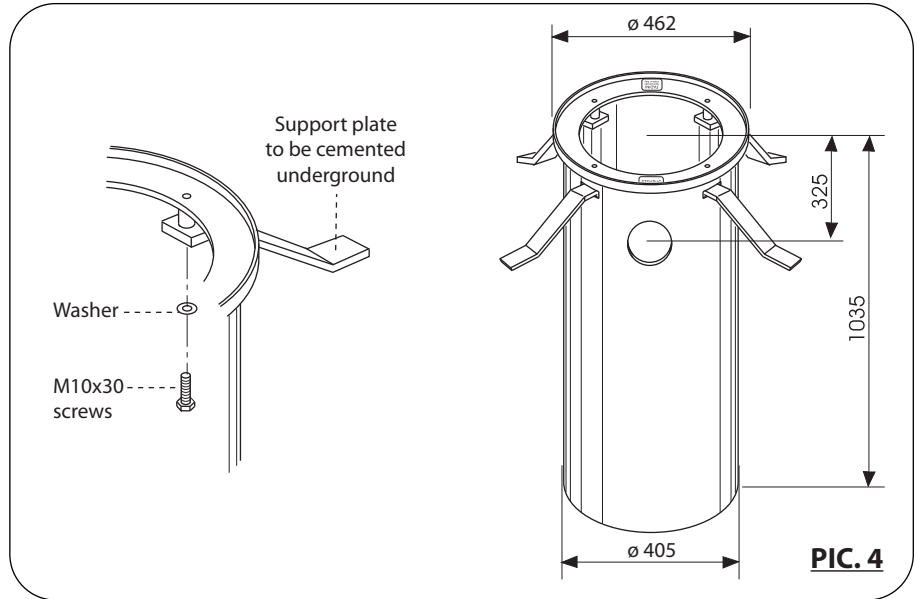

- Dig a hole measuring 80x80 cm and approximately 1,20 m deep, where the Strabuc 918 or Strabuc 930 are to be installed: these measurements are adequate for inserting and cementing the **cylindrical container** at ground level (Pic.5). Simultaneously, it is important to dig a hole in the ground to take a **corrugated flexible pipe** (max ø 50 mm) to the **cylindrical container**, passing through the hole as provided in the container, in order to house the electric wires to be connected to the **Elpro S40** electronic programmer (to be installed in a protected place).

- Before positioning the **cylindrical container**, arrange a 20 cm-deep layer of pebbles for rainwater drainage.
It is important that once the cylindrical container has been placed on the pebbles, the upper portion is flush with the ground level.

 **IMPORTANT: take care to avoid power or water pipes when digging. Arrange a water drainage layer beneath the dig.**

 **IMPORTANT: once the housing has been positioned, before cementing, use a spirit level to ensure that it is absolutely level, to allow perfect vertical movement of the traffic control post.**

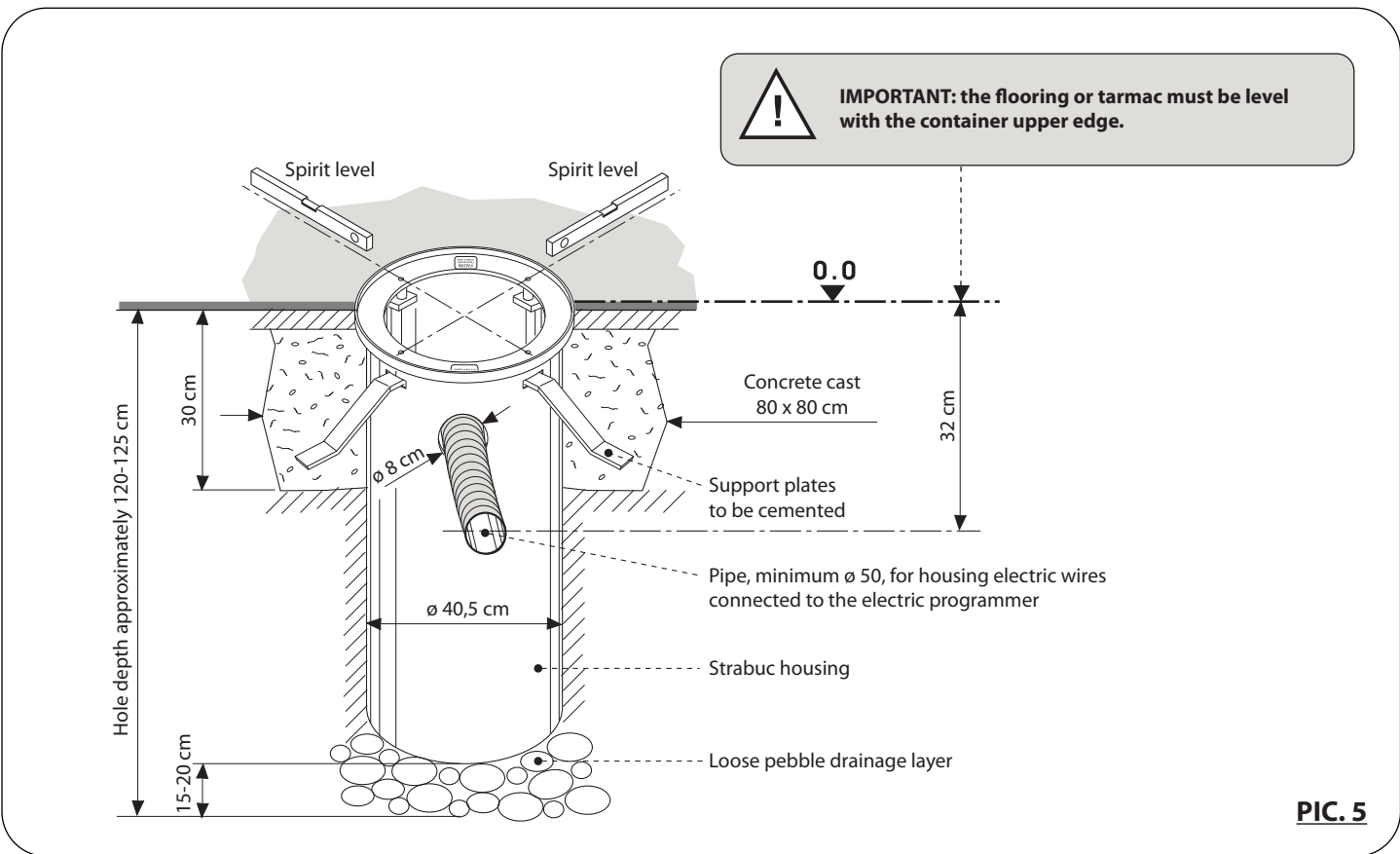

INSTALLATION OF THE STRABUC 918 OR STRABUC 930 TRAFFIC CONTROL POST

Once the cement has set, proceed with installation of the traffic control post inside the **cylindrical container**. For this operation, it is necessary to use equipment suitable for hoisting and then placing it in the post seat, by hitching to the **eyebolt** on the top of the **retracting post cover**, having unscrewed and removed the three screws and the **cover**. Before placing the Strabuc 930 inside the cylindrical container, pass all the electric wires through the corrugated tube connected to the Elpro S40 programmer: for this initial phase, use a pull-out to be passed through the pipe first (Pic. 6 and Pic.10).

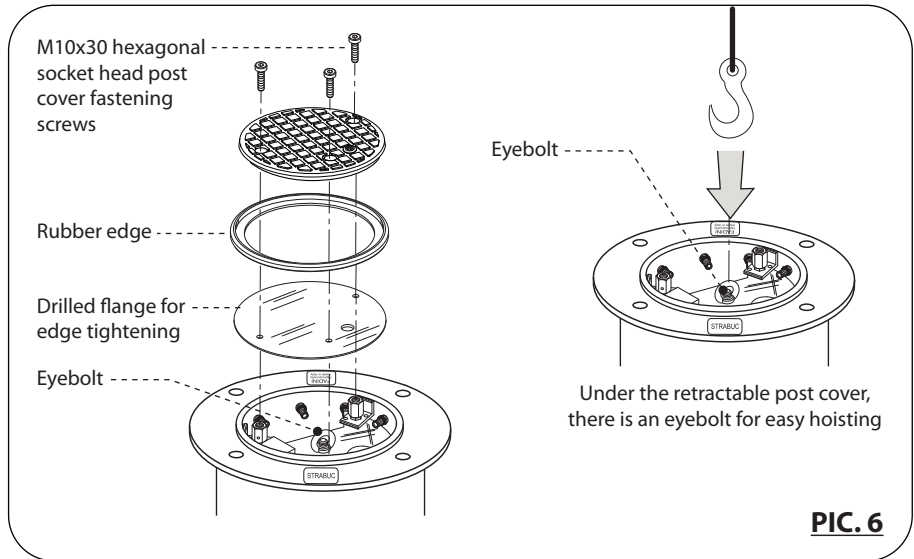

INSTALLATION OF THE STRABUC 930 HEAVY ARMoured (WITH ARMoured LOCK BARREL)

Before installing the Strabuc 930 Heavy Armoured version (with **Armoured Lock Barrel**) the traffic post must be connected to the 230 Volt power supply (1). Raise the post about **20 cm** (2) and switch off the power supply (3) (Pic.7).

N.B. We recommend to fit a 20 μ F capacitor in parallel to the two phase/live wires to give the traffic control post more power on starting.

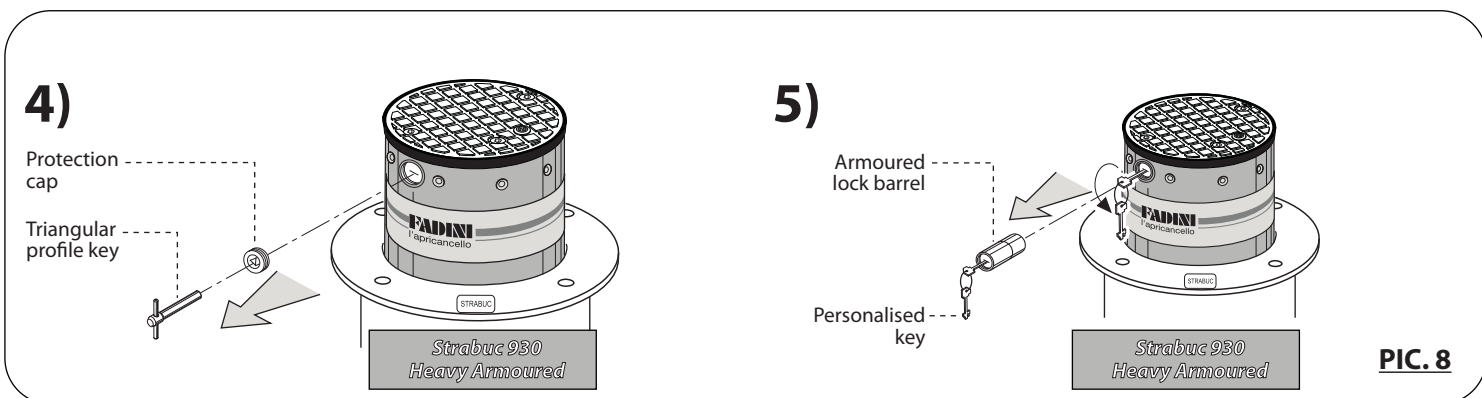
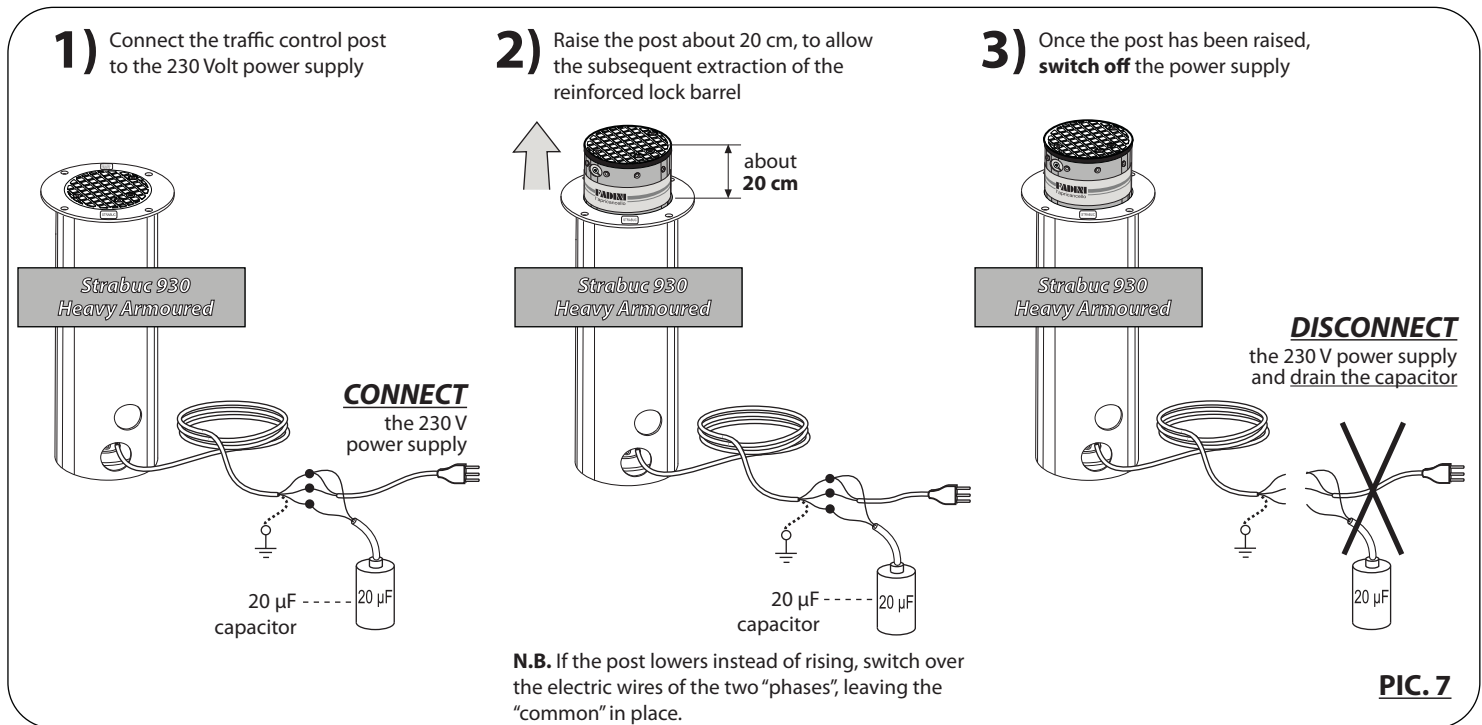

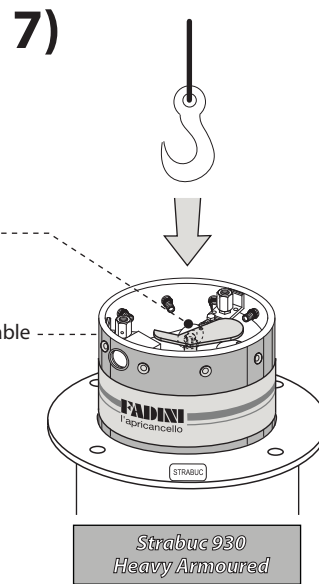
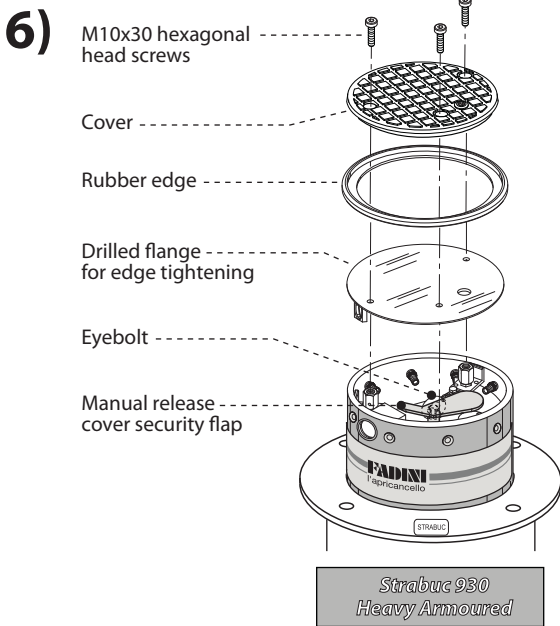

PIC. 9

ATTENTION: as Strabuc 918 or Strabuc 930 come complete with a series of electric cables, each one 10 metres long, during all these traffic post installation operations, **never tug at or charge electric wires for any reason.** During Strabuc 918 or Strabuc 930 maintenance or removal operations **DO NOT CUT THE ELECTRIC WIRES**, remove them from the pipes.

ATTENTION: measure the distance between the traffic post installed and the Elpro S40 programmer: once the Strabuc has been positioned and fastened, all the electric cables must rest freely on the bottom of the cylindrical housing. If the distance is greater, the wires should be extended using sealed joints (junction boxes) inside an accessible dividing box, according to good installation practice: this will prevent malfunctions and will guarantee efficient operation over time.

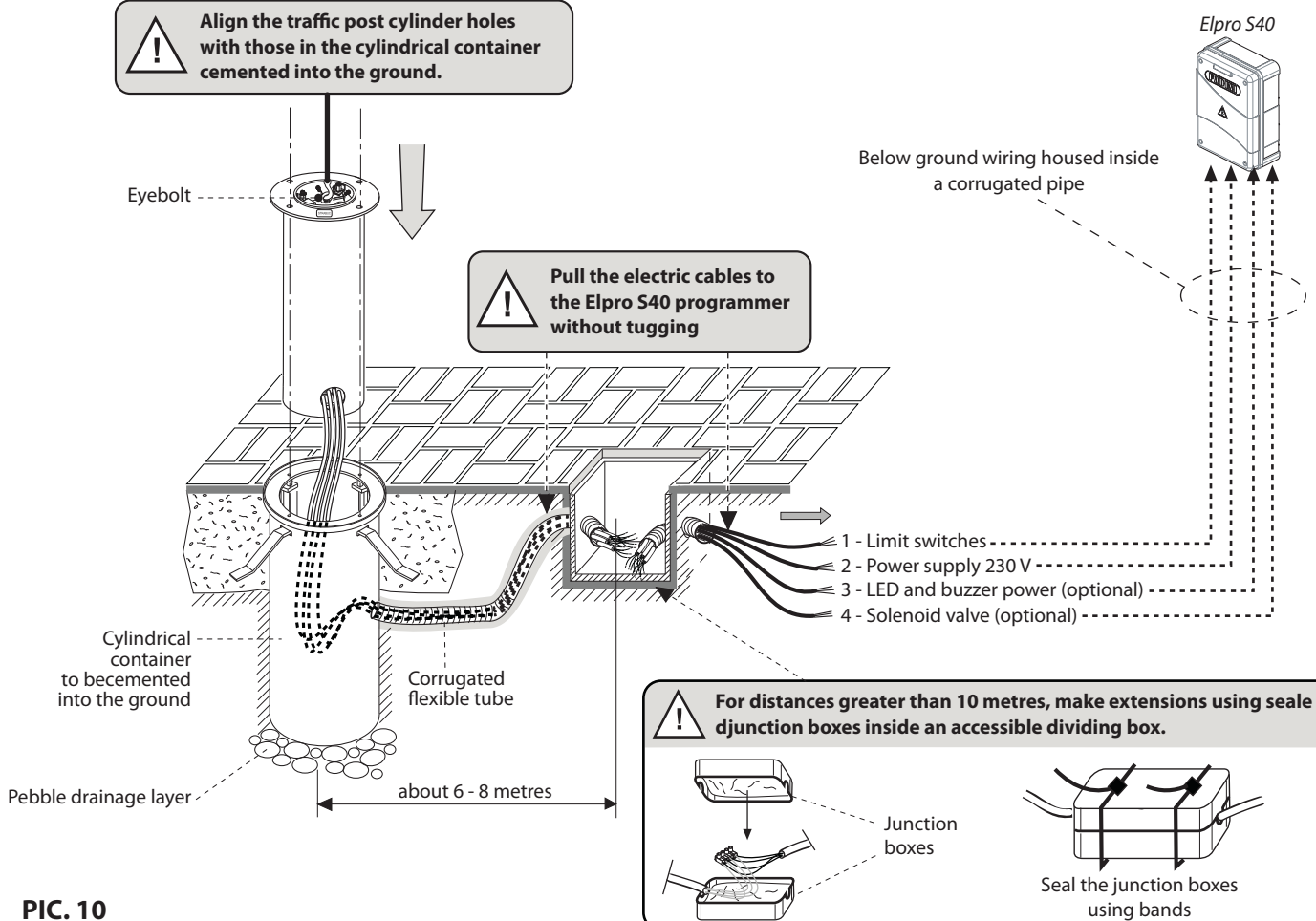

PIC. 10

Once all the electric wires have been put in place, terminate by fastening the **Aluminium collar** and the **Cover**: lubricate the fixing screws of the collar and retractable post cover using grease (Pic. 11).

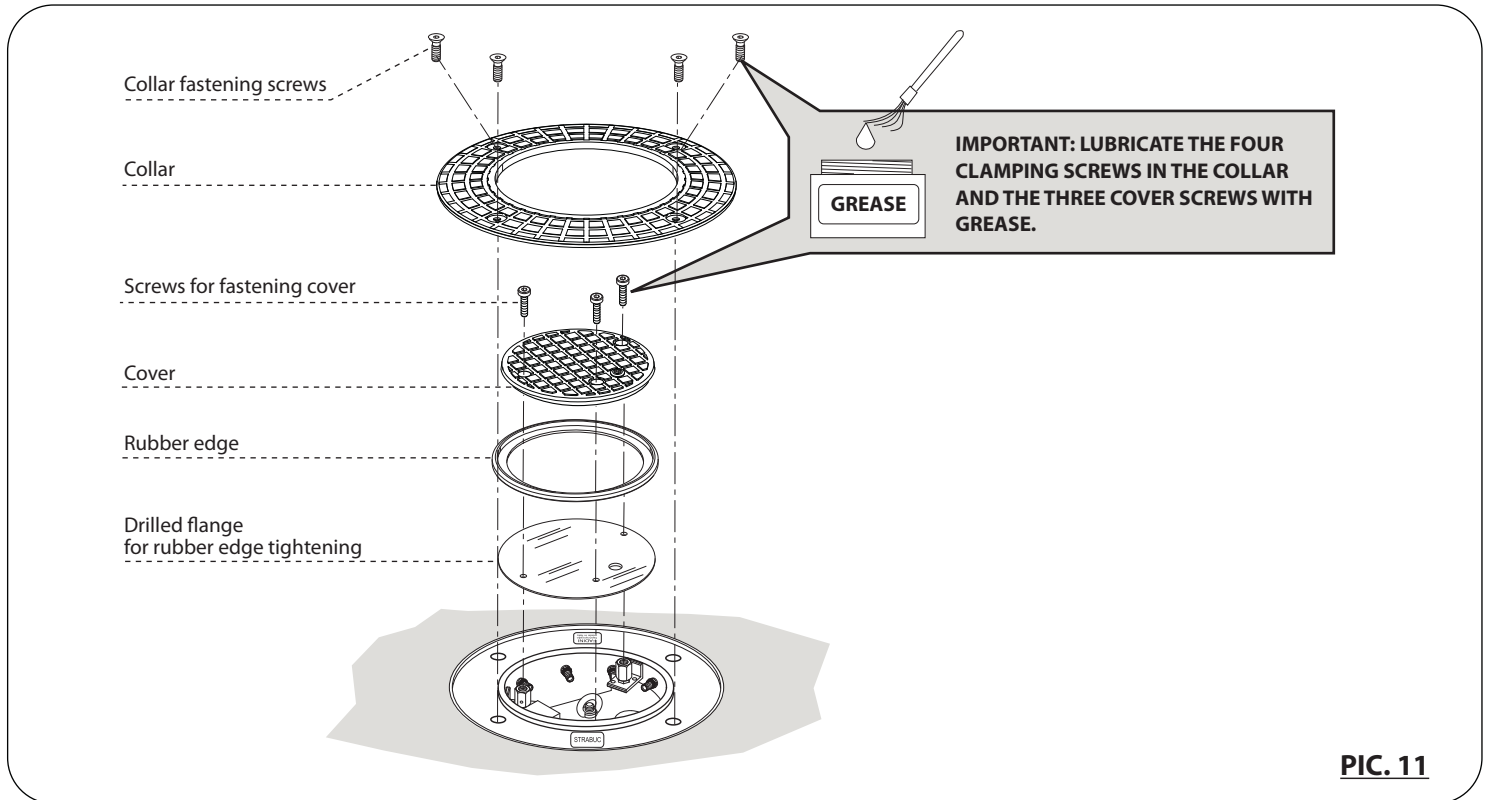

ARRANGING THE MAGNETIC COILS

IMPORTANT: check that there are no sources of disturbance such as to conceal or influence the magnetic/electromagnetic detections of any metal detector coils in the immediate vicinity of the installation accessories.

The magnetic coil safety accessory is always activated to detect transiting road vehicles. It prevents the traffic post from rising when vehicles pass over the coils. A hole must be prepared (see relative instruction sheet). Specifications should always be observed for correct magnetic coil operation.

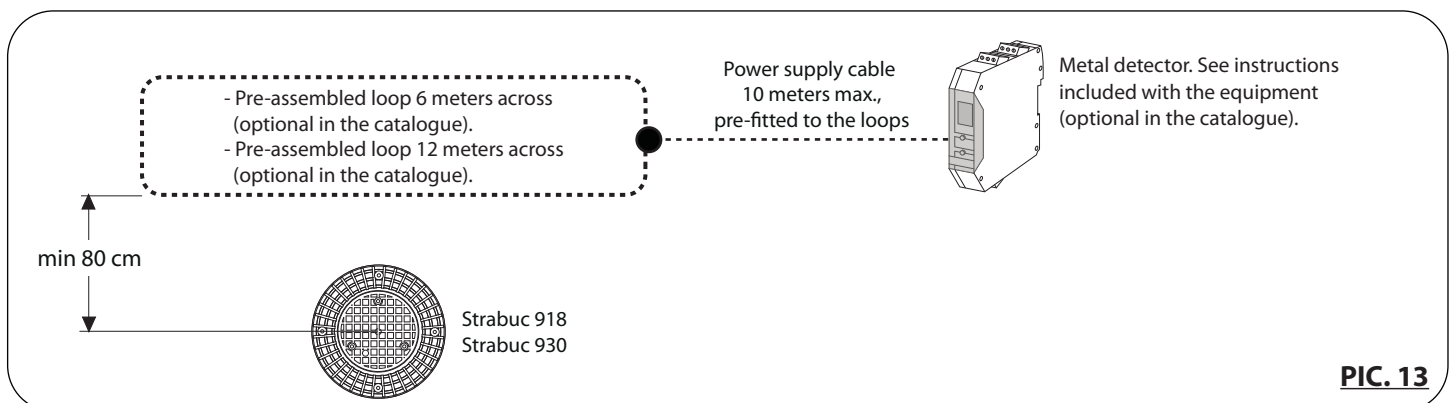
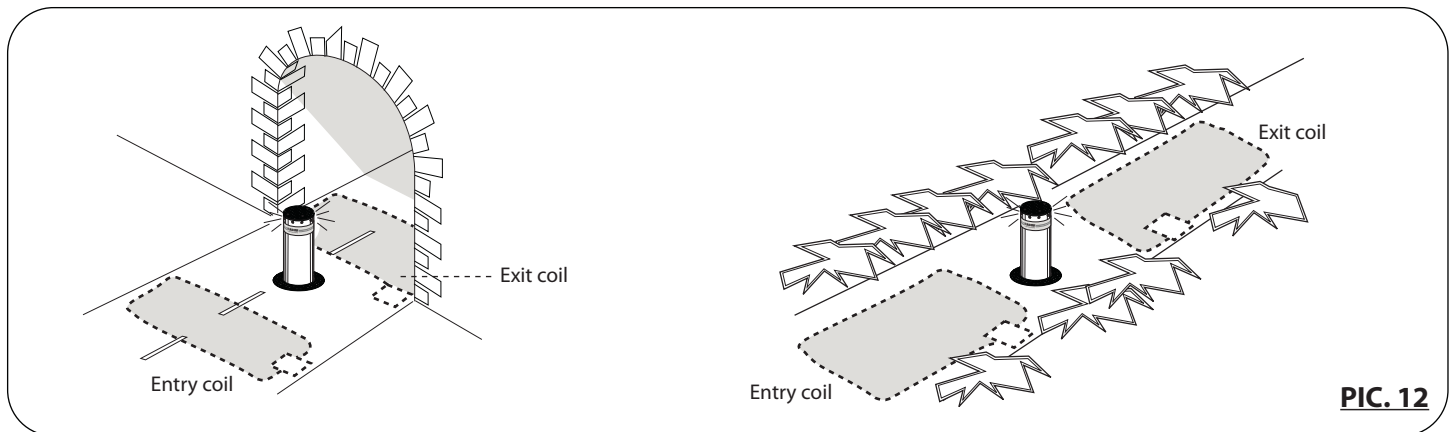

ARRANGEMENT OF THE PHOTOELECTRIC CELLS

The photoelectric cells must be installed at a minimum working distance as indicated in Pic. 14.

ARRANGEMENT OF VISUAL 344

The 2 or 3-module Visual 344 is a metal accessory used to house the Elpro S40 in exposed positions, in those installation situations in which the programmer cannot be wall- or recess-mounted. It has also been designed for the installation of possible control accessories such as intercom systems or key switches, in the immediate vicinity of the traffic post (pic. 12).

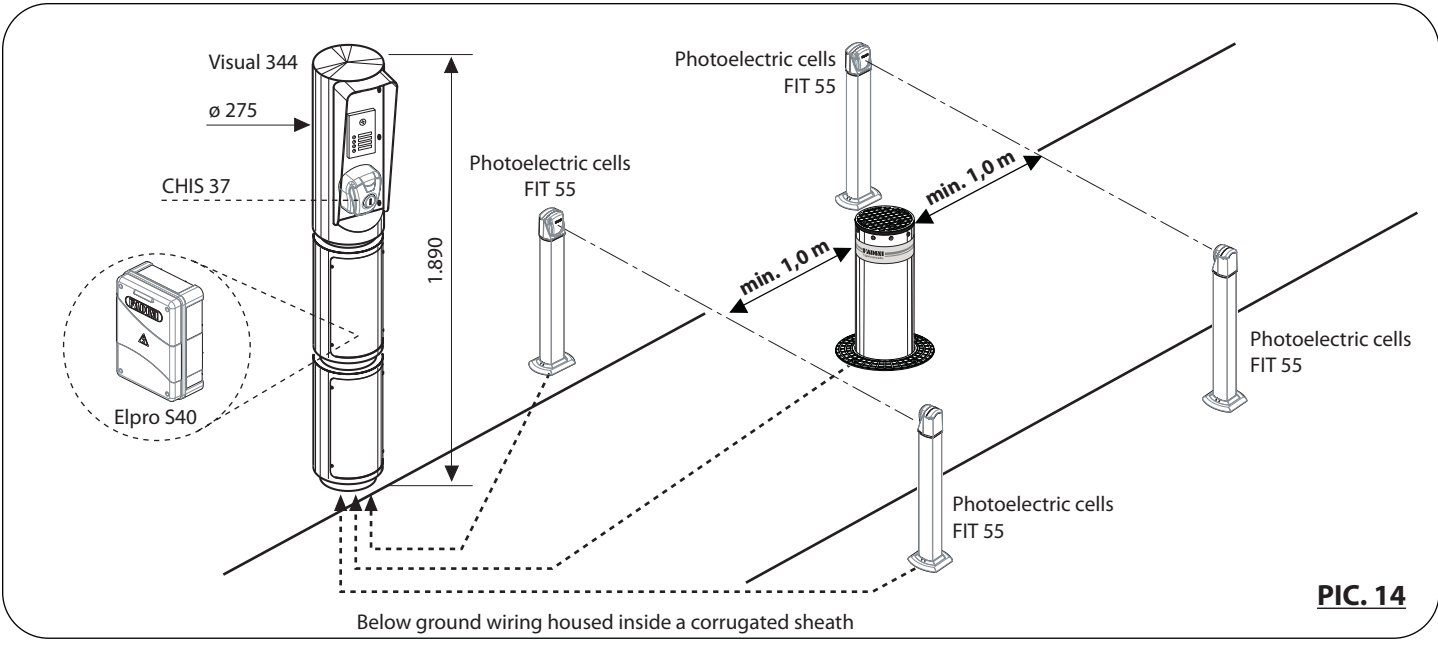

PIC. 14

DIAGRAM OF THE ELECTRICAL CABLES OF THE BOLLARD

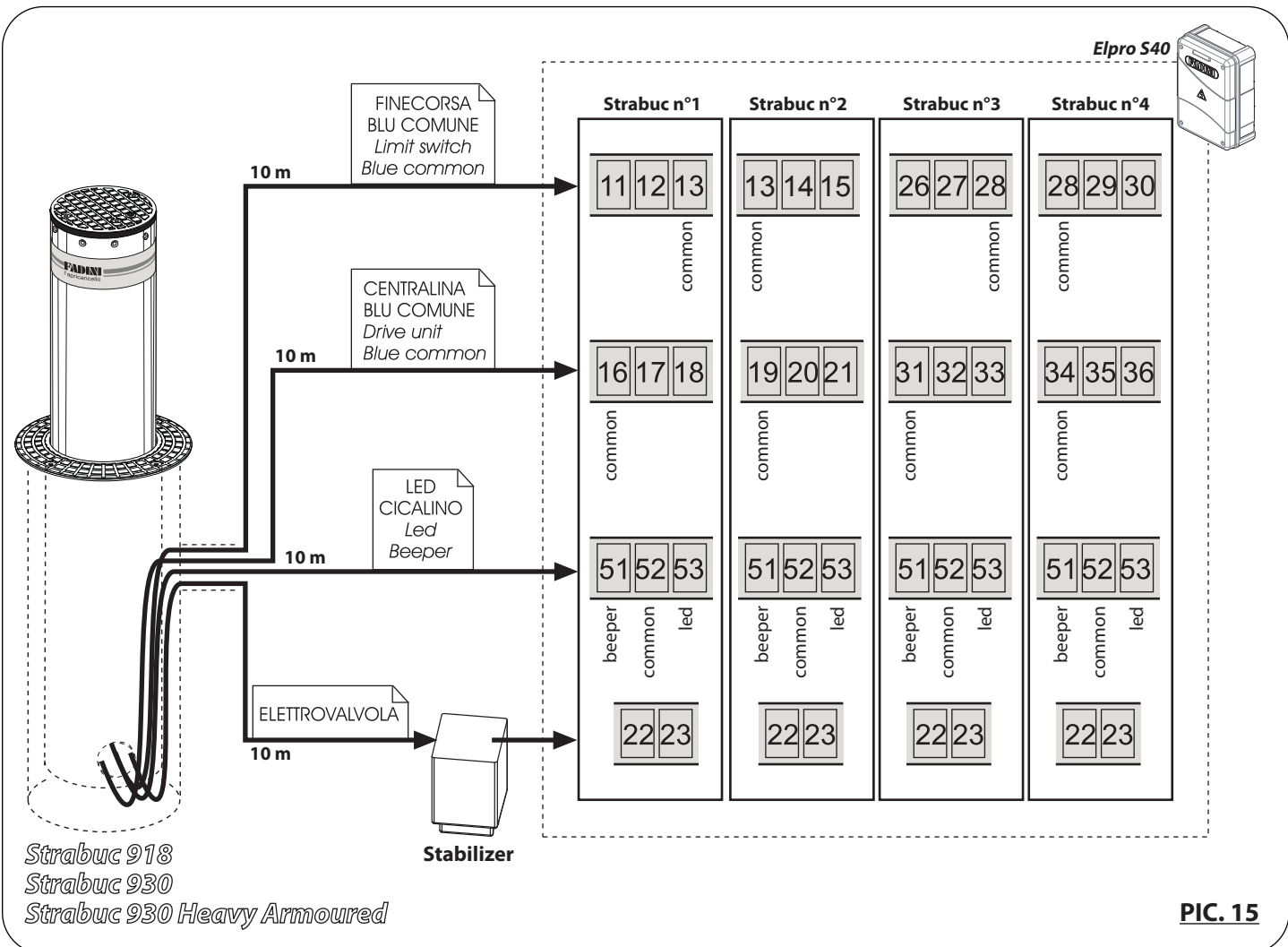

PIC. 15

ELECTRICAL CONNECTIONS TO THE ELPRO S40 CONTROL BOARD

General description: the electronic panel Elpro S40 is fitted with a microprocessor to manage up to four retractable traffic controlposts in the Strabuc series. With its single-phase 230 V power supply, it satisfies the Low Voltage 2006/95 CE and Electromagnetic Compatibility 2004/108/CE safety standards and should therefore be installed by a qualified technician in compliance with applicable regulations.

Elpro S40 stands out for its ability to monitor system faults and malfunctions (ISC).

ISC = Integrated Supervision Circuit is a special Elpro S40 feature that monitors the whole electronic board aimed at detecting any component faults, or system accessory malfunction, if the operator is fitted with a release solenoid valve this allows the retractable post to lower.

The **Elpro S40** programmer should be installed in a dry, protected place, inside its own container or, in the case of additional components for operating the control and safety accessories, it should be housed inside a Visual 344 or a cabinet certified for external use.

- The **Elpro S40** programmer is powered using electric wires with a 1,5 mm² section, with a cut-off differential switch over a maximum distance of 50 metres.

For distances of over 50 metres we recommend using electric cables with appropriate sections according to good installation practice. For all accessories external to the electric panel, electric cables with 1 mm² wires may be used.

- The three-light traffic lights must be connected by a 4 x 1,5 mm² wire electric cable and the card powered 230 V to terminals 60-61 on the plug-in card.

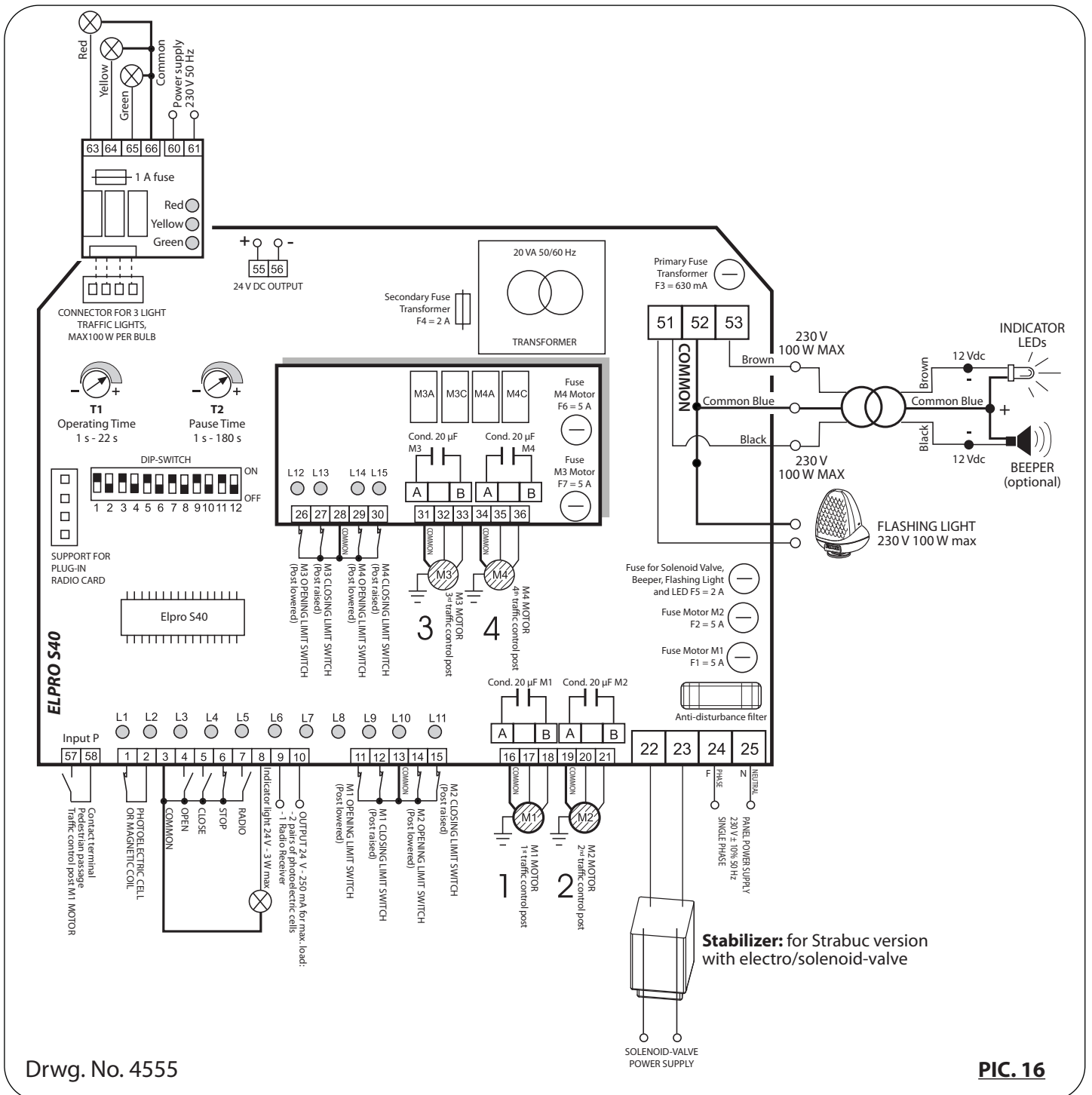

FIRST OPERATION MANOEUVRES

ATTENTION: do not power the system until all the wiring needed for operation has been performed.

Make the electrical connections to the limit switches, then supply with electric power and check the LED status first of all: with the post in down position LED No. L8 must be OFF and LED No. L9 ON, otherwise swap the connections to terminals 11 and 12.

Strabuc n°1
11 12 13
FINECORSA BLU COMUNE
Limit switch
Blue common

Strabuc n°1
11 12 13
FINECORSA BLU COMUNE
Limit switch
Blue common

Strabuc 918 or Strabuc 930 with solenoid valve
22 23
Stabilizer
ELETTOVALVOLA

ATTENTION: it is required that the post stay completely lowered: should the post rise during installation, override by the release key and lower the post manually, then tighten again.

L8 = Limit switch open M1, normally ON, it goes off when the post is in down position

L9 = Limit switch close M1, normally ON, it goes off when the post is in up position

PIC. 17

Having terminated installation of the traffic control post and all the safety and control accessories (all of the NC contacts on the Elpro S40 board are to be bridged - pic.18), and the respective connections with the Elpro S40 programmer, and having completed thorough risk analysis, the first operation manoeuvres can be performed.

If you have a radio transmitter, encode the radio receiver according to the relative instructions before giving the command to raise the retractable post, or give the manoeuvre command using a key switch. Once power is supplied, connect the motor/pump cable and, satisfied that the limit switch LEDs are properly alight, the post should move up on the first commanding pulse; **should it fail, disconnect power supply and swap the connections to the live terminals.**

NC

All NC contacts are to be closed

230 V

PIC. 18

20 µF

A B

Strabuc n°1
16 17 18
CENTRALINA BLU COMUNE
Drive unit
Blue common

Should the motor fail to drive the post up by first pulsing, swap the connections to the electric motor live terminals only

Strabuc n°1
16 17 18
CENTRALINA BLU COMUNE
Drive unit
Blue common

1st pulse

Strabuc 918 or Strabuc 930 in raised position: **Access Closed**

In case of multiple installations go through the same procedure with each post

PIC. 19

VERSION OF STRABUC 918 OR STRABUC 930 WITH SOLENOID VALVE

In the version with solenoid valve no manual overriding action is needed, and in case of power failure the post descends automatically flush with pavement level. To enable the solenoid valve to operate properly, the electric wires labelled "ELETTOVALVE" from the post assembly are to be connected, through the voltage stabilizer, to terminals 22 and 23 in the Elpro S40 control box (pic. 20).

Strabuc 918 or Strabuc 930 with solenoid valve
22 23
Stabilizer
ELETTOVALVOLA

230 V

Strabuc 918 or Strabuc 930 with solenoid valve

230 V

NO

Strabuc 918 or Strabuc 930 with solenoid valve

PIC. 20

RELEASE OPERATIONS FOR MANUAL LOWERING OF STRABUC 918 OR STRABUC 930

The traffic control post is fitted with a system for manual post lowering. The universal triangular-recess key provided removes the protection plug and subsequently releases the retracting traffic control post, which lowers to pavement level with simple manual pressure (pic. 21). Once the post has been lowered manually, it only rises again following an electrical command impulse.

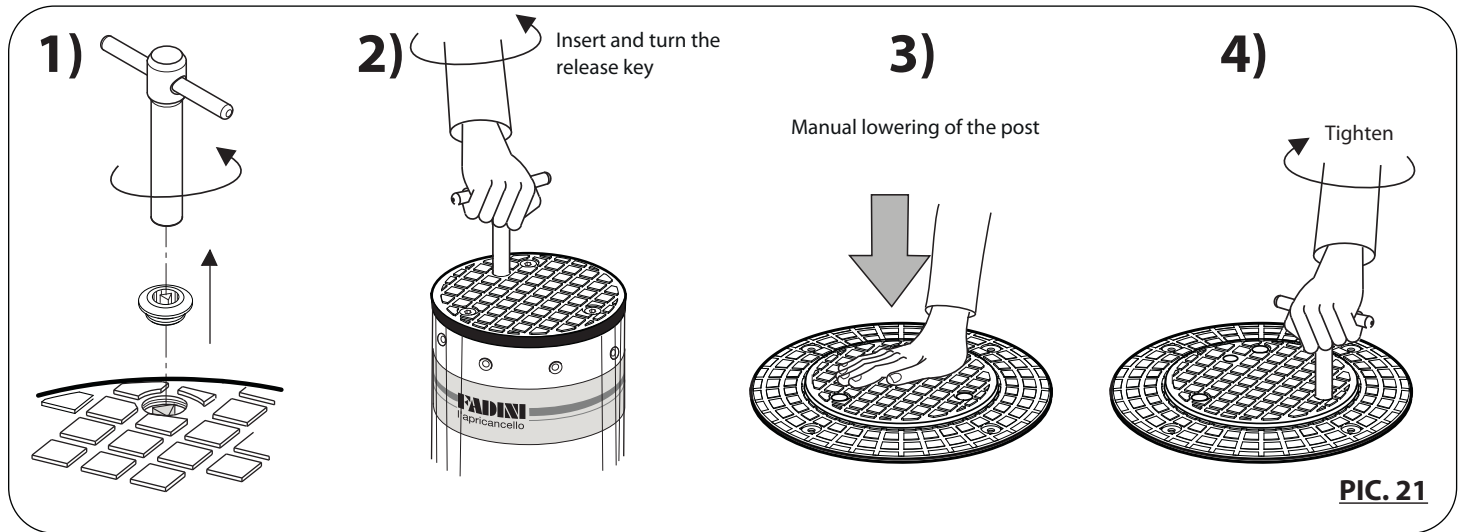

RELEASE OPERATIONS FOR MANUAL LOWERING OF THE STRABUC 930 HEAVY ARMoured

Strabuc 930 Heavy Armoured posts can be lowered manually by following the operations shown in picture 22.

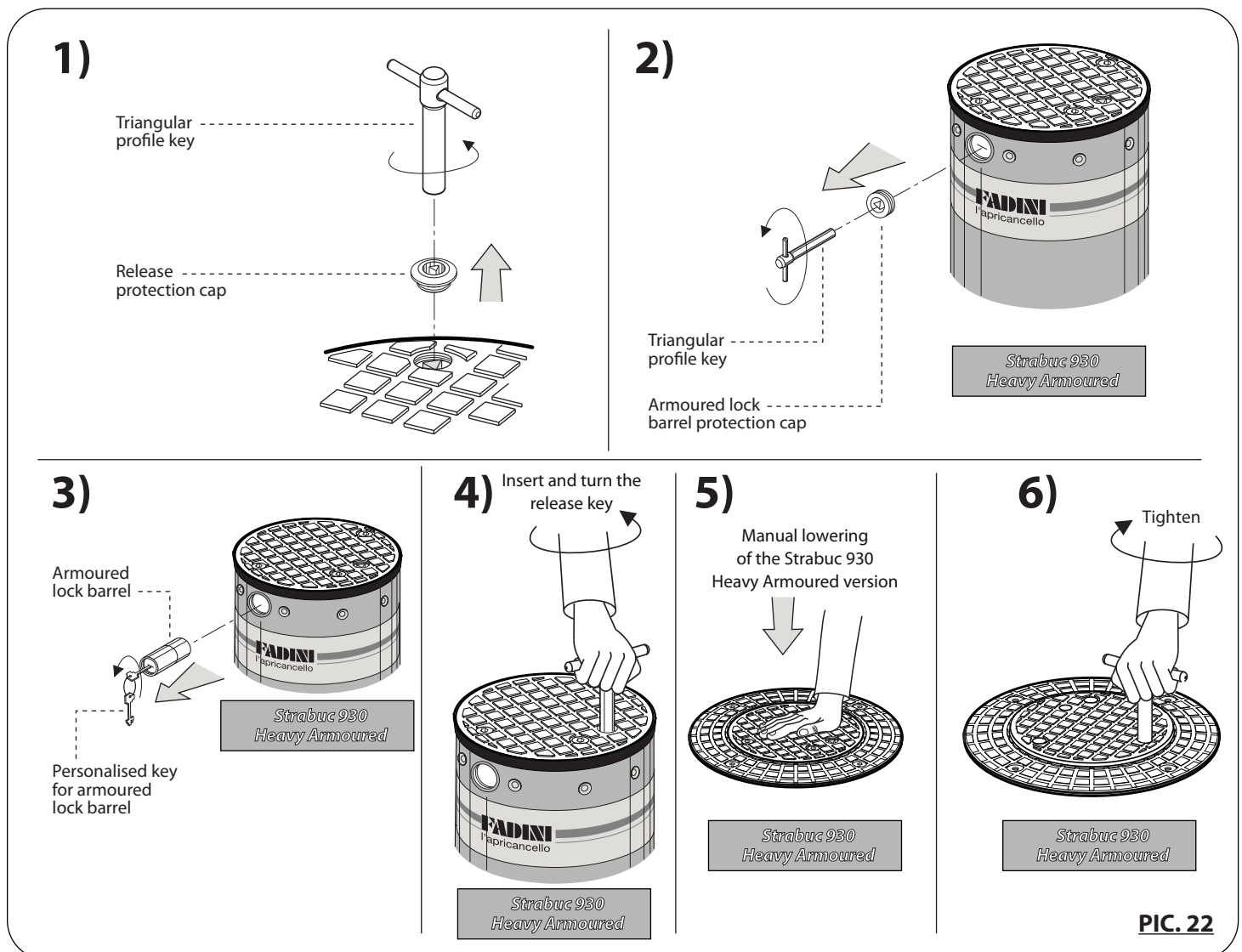

REMOVING ONLY THE POST OF STRABUC 930 HEAVY ARMOURED

It is possible to remove Strabuc 930 Heavy Armoured from its seat by following steps 1) and 2) as described in pic. 23. But in order to remove only the retractable post, carry on with the steps as subsequently described in pic. 23.

1)

2)

- VIEW FROM BELOW -
CYLINDRICAL HOUSING

3) To remove only the retractable post: with the Strabuc 930 Heavy Armoured version raised using the winch, **unscrew the three clamping nuts** and respective washers, positioned below the Cylindrical container.
ATTENTION: during this operation the cylindrical housing will drop: it is therefore recommended to support it.

Clamping nuts and washers

! IMPORTANT: do NOT loosen or tighten the three axial alignment dowels of the internal group.

4) Unscrew the **Cap** protecting the **Armoured lock barrel** using the triangular profile key

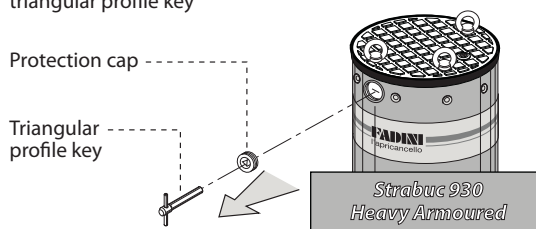

5) Remove the whole **Reinforced Lock Barrel** by inserting the personalised key and turn anticlockwise

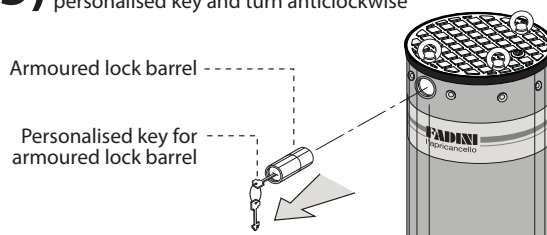

6) Remove the three **Eyebolts**, the post **Cover**, the **Rubber edge** and the **Drilled flange**

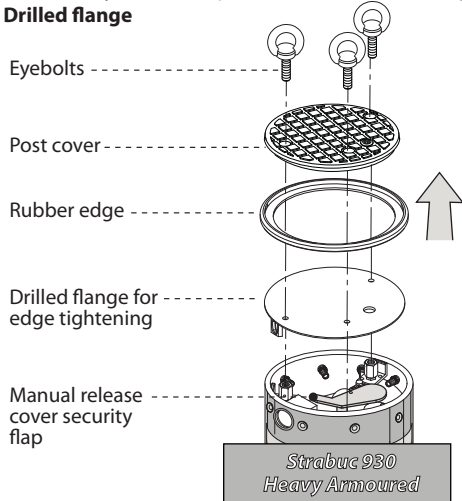

7) Unscrew the three **long hexagonal nuts** with their respective **Clamping screws** and remove the **Retractable post** to leave the **Piston - hydraulic main unit** set exposed

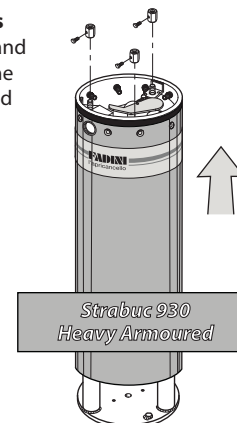

! ATTENTION: during the assembly phase it is important to reposition the internal unit in exactly the same position as before without screwing or loosening the three axial alignment dowels.

PIC. 23

RESISTANCE DATA

Strabuc 918

Static load resistance:

The static load acting on the Strabuc 918 when completely lowered is considered as the weight a 20.000 kg lorry exerts when parked on or passing over the traffic control post.

Practical tests with fully laden lorries have confirmed this result.

Maximum static load **20.000 kg**

Strabuc 930

Static load resistance:

The static load acting on the Strabuc 930 when completely lowered is considered as the weight a 20.000 kg lorry exerts when parked on or passing over the traffic control post.

Practical tests with fully laden lorries have confirmed this result.

Maximum static load **20.000 kg**

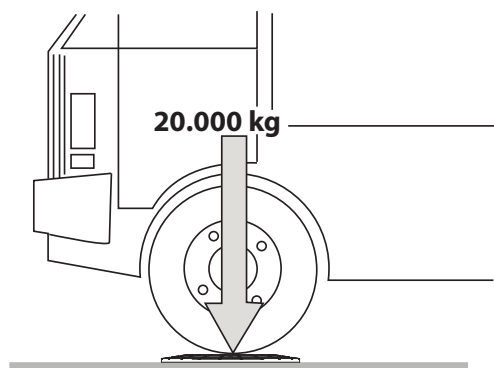

PIC. 24

VIOLENT COLLISION RESISTANCE

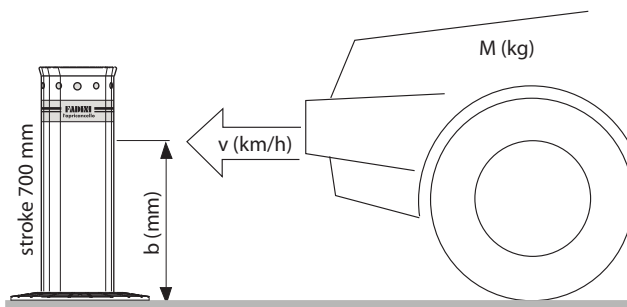

Strabuc 918

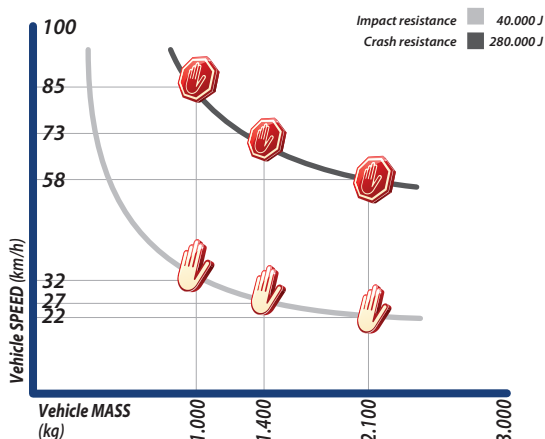

Strabuc 930

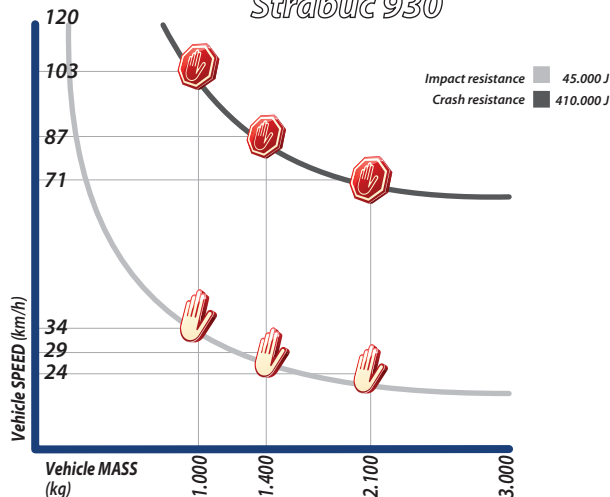

Various factors, such as the compaction index, soil permeability coefficient and kind of concrete may reduce the values indicated in the diagram even significantly.

Various factors, such as the compaction index, soil permeability coefficient and kind of concrete may reduce the values indicated in the diagram even significantly.

PIC. 25

**DECLARATION OF CONFORMITY
of the Manufacturer**

Manufacturing
company:



**meccanica
FADINI** snc.

Via Mantova, 177/A - 37053 Cerea (VR) Italy
Tel. +39 0442 330422 r.a. - Fax +39 0442 331054
e-mail: info@fadini.net - www.fadini.net

hereby declares under its own responsibility that:

Model:

STRABUC 918

Oil-hydraulic bollard, fully retractable into the ground,
for traffic control in public areas

IS IN COMPLIANCE WITH THE NORMS **2006/42/CE**

and that:

Strabuc 918 is to be sold and installed as a comprehensive "Automatic System", including the accessories and components as recommended by the Manufacturing Company. In observance of the current directives, any automation is to be regarded as a "machine". Therefore it is required that all the applicable safety norms are strictly complied with by installation agents, who are also required to issue a Declaration of Conformity.

The manufacturing company is not liable for incorrect applications or misuse of its products that are declared to be produced in compliance with the following norms:

- Analysis of the risk and actions to cure them: **EN 12445 & EN 12453**
- Low Voltage Directive: **2006/95 CE**
- Electro-magnetic Compatibility Directive: **2004/108/CE**

In order to certify the product the Manufacturer declares under his own responsibility the compliance with the PRODUCT regulations under the NORMS EN 13241-1

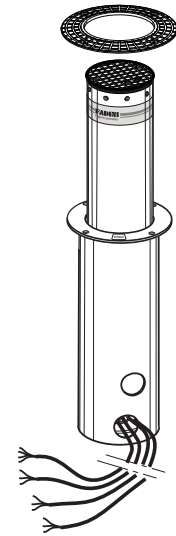

GB

Date: 10-01-14

Meccanica Fadini s.n.c.
Responsible Manager



The Responsible Manager

**DECLARATION OF CONFORMITY
of the Manufacturer**

Manufacturing
company:



**meccanica
FADINI** snc.

Via Mantova, 177/A - 37053 Cerea (VR) Italy
Tel. +39 0442 330422 r.a. - Fax +39 0442 331054
e-mail: info@fadini.net - www.fadini.net

hereby declares under its own responsibility that:

Model:

STRABUC 930

Oil-hydraulic bollard, fully retractable into the ground,
for traffic control in public areas

IS IN COMPLIANCE WITH THE NORMS **2006/42/CE**

and that:

Strabuc 930 and *Strabuc 930 Heavy Armoured* are to be sold and installed as a comprehensive "Automatic Systems", including the accessories and components as recommended by the Manufacturing Company. In observance of the current directives, any automation is to be regarded as a "machine". Therefore it is required that all the applicable safety norms are strictly complied with by installation agents, who are also required to issue a Declaration of Conformity.

The manufacturing company is not liable for incorrect applications or misuse of its products that are declared to be produced in compliance with the following norms:

- Analysis of the risk and actions to cure them: **EN 12445 & EN 12453**
- Low Voltage Directive: **2006/95 CE**
- Electro-magnetic Compatibility Directive: **2004/108/CE**

In order to certify the product the Manufacturer declares under his own responsibility the compliance with the PRODUCT regulations under the NORMS EN 13241-1

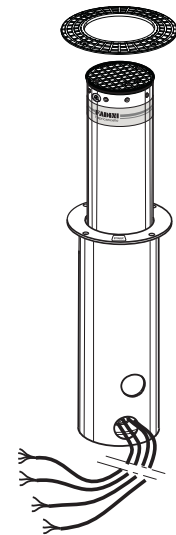

GB

Date: 10-01-14

Meccanica Fadini s.n.c.
Responsible Manager



The Responsible Manager

ELECTRIC MOTOR

Power output	0,25 kW (0,33 HP)
Power consumption	330 W
Power supply voltage	230 V
Frequency	50 Hz
Absorbed current	1,8 ÷ 3,5 A (6 A max)
Motor rotation speed	2.800 rpm
Intermittent service	S3

CYLINDRICAL CONTAINER - to be cemented

Material	"FE" sheet steel
Treatment	Hot dip galvanization
Calandered sheet metal thickness	1,5 mm
Fixing flange thickness	10 mm
4x support plates	flat 40x10
Total weight	30 kg

Strabuc 918

Post diameter	Ø 275 mm
Post thickness	4 mm
Post height	700 mm
Plunger diameter	30 mm
Rod diameter	16 mm
Net rod travel	740 mm
Calibrated thrust	18 daN
Frequency of use	very intensive
Rising time	~ 6,1 s
Lowering time	~ 5,7 s
Protection class - Strabuc 918	IP 67
LED power supply	230 V - 50 Hz
LED lights	24 V
Post finishing	Powder coating polyester RAL 1028 - Melon yellow
Post material	"FE 360" steel
Stainless Steel/Inox version	"AISI 304"
Impact resistance	40.000 J
Crash resistance	280.000 J
Maximum static load	20.000 kg
Complete weight of Strabuc 918	140 kg

OIL-HYDRAULIC MAIN UNIT

Hydraulic pump	P10
Pump flow rate	4,45 litres/1'
Operating pressure	2 MPa (20 bar)
Max pressure	3 MPa (30 bar)
Operating temperature	- 20 °C + 80 °C
Oil container capacity	1,5 litres
Oil type	Oil Fadini - code 708L
Protection class	IP 67 (IP 65 with electrovalve)

Strabuc 930 - Strabuc 930 Heavy Armoured

Post diameter	Ø 275 mm
Post thickness	12 mm
Post height	700 mm
Plunger diameter	30 mm
Rod diameter	16 mm
Net rod travel	740 mm
Calibrated thrust	18 daN
Frequency of use	very intensive
Rising time	~ 11,6 s
Lowering time	~ 9,9 s
Protection class - Strabuc 930	IP 67
LED power supply	230 V - 50 Hz
LED lights	24 V
Post finishing	Powder coating polyester RAL 7016 - Anthracite gray
Post material	"FE 360" steel
Impact resistance	45.000 J
Impact resistance	410.000 J
Maximum static load	20.000 kg
Complete weight of Strabuc 930	180 kg

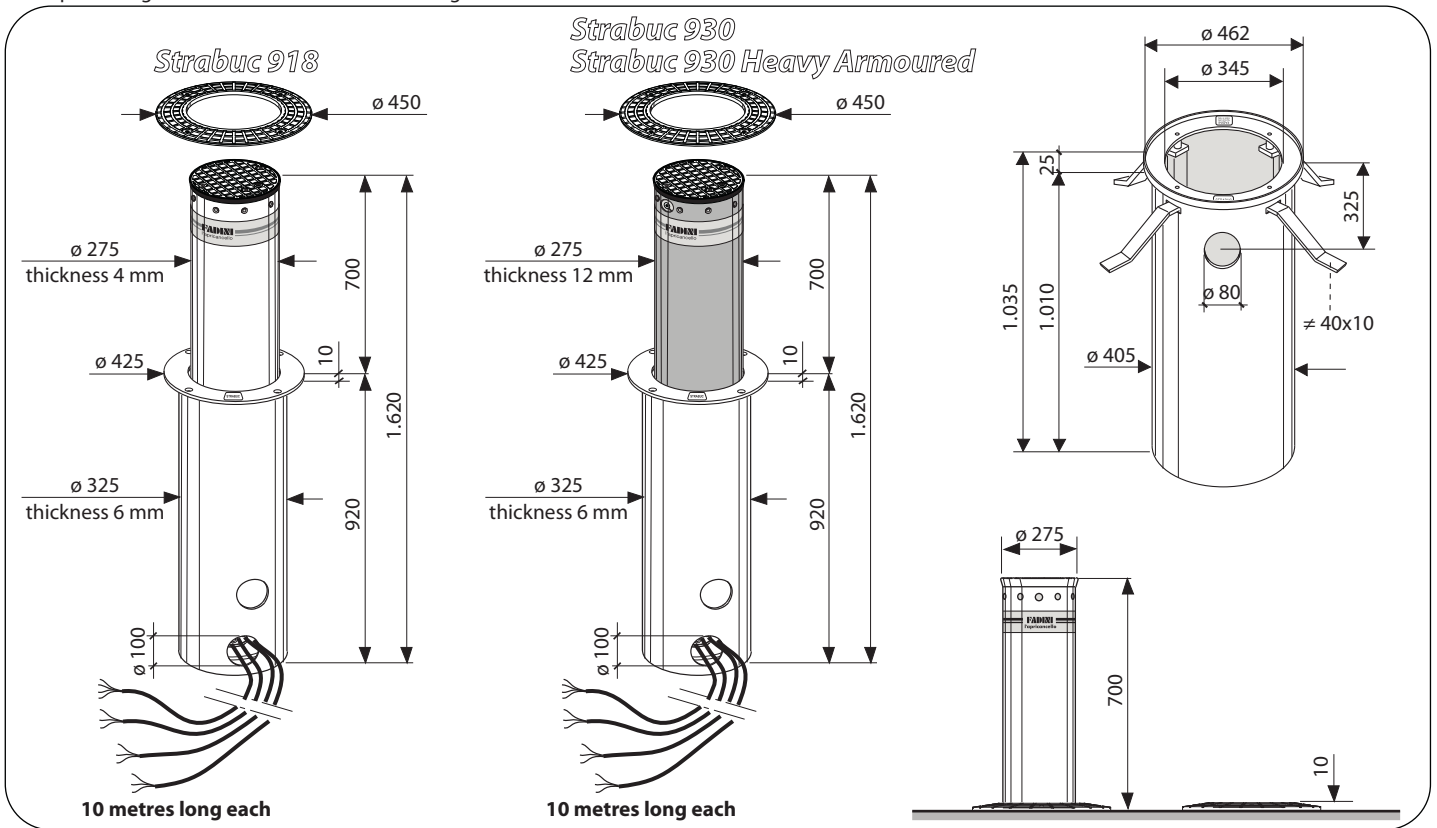
**IF THE OPERATOR IS REMOVED**

- 1° - Disconnect the main switch before opening the lid of the electric cable junction box.
- 2° - **Do not cut the electric wires**, rather remove them from the terminal board loosening the clamping screws inside the dividing box.

ORDINARY MAINTENANCE AND WASTE DISPOSAL

For optimal performance of the system over time and operation in compliance with safety regulations, correct maintenance and checks must be performed on the operator, the electronic equipment constituting the installation and on wiring performed. The entire installation should be carried out by authorized technicians, who are also to fill in the Maintenance Form as indicated in the Norms Book (available on request):

- 1° - Oil-hydraulic operator: maintenance check every 6 months.
- 2° - Electronic equipment and safety systems: a monthly maintenance check.
- 3° - Ordinary and extraordinary maintenance to be agreed upon between end user/contractor and installation agent.
- 4° - **Packaging materials such as cardboard, nylon, polystyrene, etc. should be disposed of using specialised waste collection firms.**

The manufacturer reserves the right to make amendments to this manual without prior notice and declines all responsibility for any errors, personal injury or damage to property.

2019/04